



# 300 Series Regulators

## 307 Series Regulator

Single Stage

Rear Inlet

Chrome-Plated Brass Barstock Body

### Four-Port Configuration

The 307 Series regulators are intended for secondary pressure control of non-corrosive, high purity or liquefied gases or as point of use pressure control in high purity gas distribution systems.

### Advanced Features

- Chrome-plated brass barstock body  
Smooth surface finish
- Rear panel-mountable  
Easy installation
- Pressure ranges 0-15 to 0-200 PSIG  
Broad range of applications
- 3000 PSIG inlet pressure rating  
Safe use with high pressure cylinders

### Typical Applications

- Bulk gas distribution systems
- Gas and liquid chromatography
- High purity carrier gases
- Zero, span, and calibration gases
- High purity chamber pressurization
- Liquefied hydrocarbon gas control
- Control of cryogenic gases



307-2031 shown

### 300 Series Advantage

- Capsule® seat  
Increased serviceability and life
- 316L stainless steel diaphragm  
No inboard diffusion
- Low wetted surface area  
Minimal purge requirements
- Field-adjustable pressure limit  
Safeguard downstream equipment
- Convuluted diaphragm  
Smooth pressure changes
- Compact design  
Easily transported and integrated into systems

### Materials

- Body  
Chrome-plated brass barstock
- Bonnet  
Chrome-plated die cast zinc
- Seat  
PTFE
- Filter  
10 micron sintered bronze
- Diaphragm  
316L stainless steel
- Internal Seals  
PTFE

### Specifications

- Maximum Inlet Pressure*  
3000 PSIG (210 BAR)
- Temperature Range*  
-40°F to 140°F (-40°C to 60°C)
- Gauges*  
2" diameter chrome-plated
- Ports*  
1/4" FPT
- Helium Leak Integrity*  
1 x 10<sup>-8</sup> scc/sec
- Cv*  
0.1
- Weight (307-3031-TF4)*  
2.9 lbs. (1.29 kg)

# 300 Series Regulators

## Technical Information

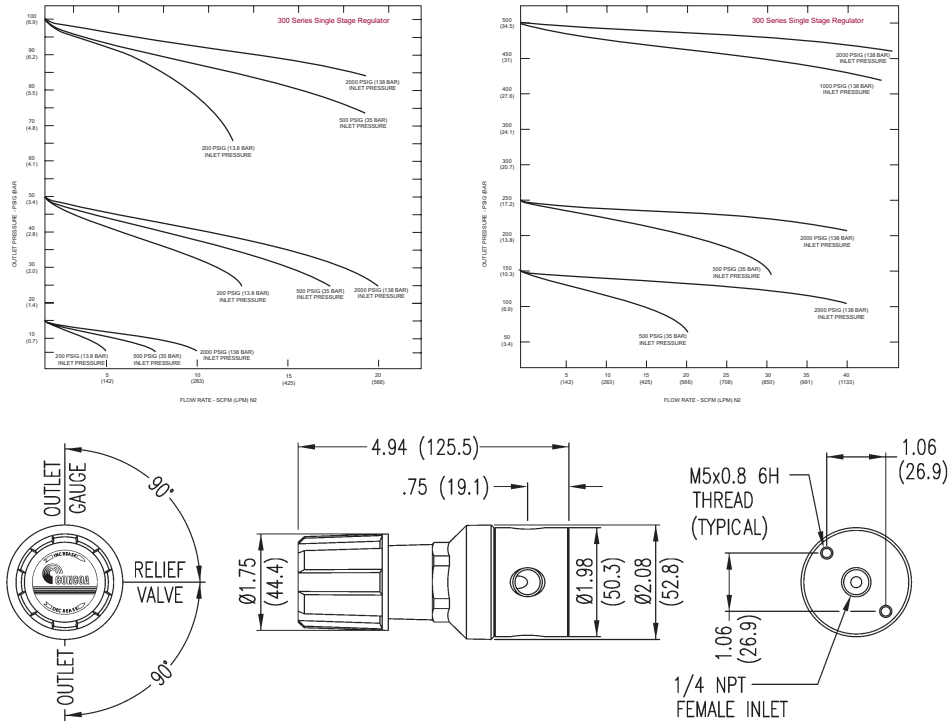

## Ordering Information

307	A	B	C	D	-Inlet	Options	
Series 307	Outlet Pressure	Outlet Gauge	Inlet Gauge	Outlet Assemblies	Assembly Gauges	Inlet Connections	Installed Options
	1: 0-15	0-30 PSIG	0: None	0: 1/4" FPT Port	0: Bare Body	000: 1/4" FPT	None
	2: 0-30	0-60 PSIG		1: 1/4" MPT	1: Standard Assembly (PSIG/kPa Gauges)	TF2: 1/8" Tube	
	3: 0-50	0-100 PSIG		2: 1/4" Tube Fitting	2: Standard Assembly (BAR/PSIG Gauges)	TF4: 1/4" Tube	
	5: 0-100	0-200 PSIG		3: Diaphragm Valve 1/4" Tube Fitting		TF6: 3/8" Tube	
	6: 0-200	0-400 PSIG		4: Diaphragm Valve 1/4" MPT		M06: 6mm Tube	
	8: 2-15 LPM CO <sub>2</sub>	2-15 LPM Flowgauge		5: Needle Valve 1/4" MPT		CGA DIN 477	
	9: Custom Calibration	Custom Flowgauge		6: 1/8" Tube Fitting		BS 341 and others available	
				7: 3/8" Tube Fitting			
				8: DISS Outlet			
				9: Diaphragm Valve 1/4" FPT			
				A: 3/8" BSP Right Hand Fitting			
				B: Diaphragm Valve 1/8" Tube Fitting			
				M: 6mm Tube Fitting			
				S: Diaphragm Valve 6mm Tube Fitting			

300 Series